

MECHANICAL

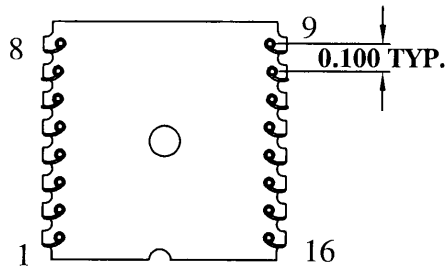

SCHEMATIC

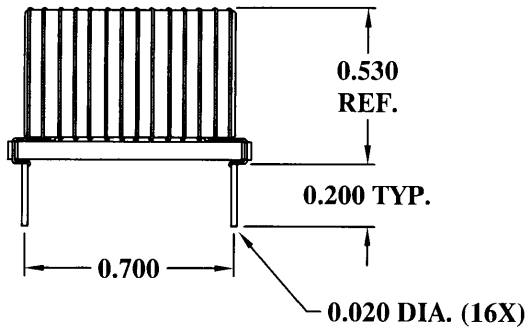
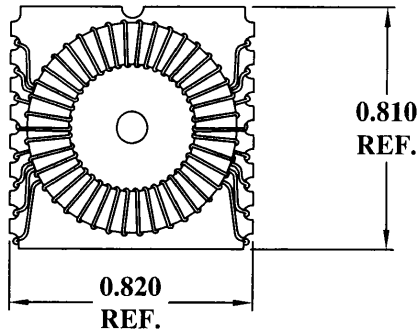
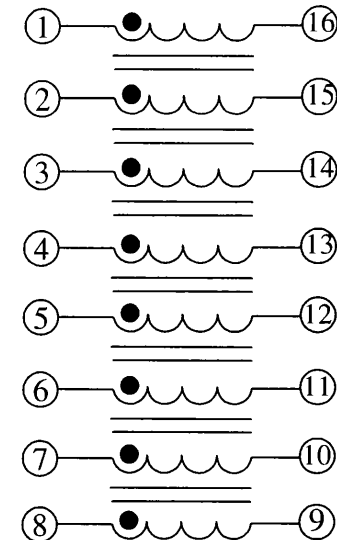

ELECTRICAL SPECIFICATIONS

URNS RATIO: 1:1:1:1:1:1:1

OPEN CIRCUIT INDUCTANCE: 4.92mH MIN. (1-16) (2-15) (3-14)
(4-13) (5-12) (6-11) (7-10) (8-9)
10 KHz 50mV

DC RESISTANCE: 0.70 OHMS NOM. (1-16) (2-15) (3-14) (4-13) (5-12)
(6-11) (7-10) (8-9)

HIGH VOLTAGE TEST: 500 VAC (1-2, 3, 4, 5, 6, 7, 8)
(2-3, 4, 5, 6, 7, 8) (3-4, 5, 6, 7, 8) (4-5, 6, 7, 8)
(5-6, 7, 8) (6-7, 8) (7-8)

				DESIGN PER:	BH CATALOG	 BH ELECTRONICS, INC. BURNSVILLE & MARSHALL, MN © 1998 BH Electronics
				<input type="checkbox"/> CUSTOM <input checked="" type="checkbox"/> NON-PROPRIETARY		
				DRAWN:	K. LOFTUS	TITLE: COMMON MODE CHOKE PART NO. 501-1209
				ENGR:	B. GASS	
C	4-10-07	REVISE MECHANICAL	5/6	UNLESS OTHERWISE SPECIFIED: DIMENSIONS IN INCHES, TOLERANCES NON-CUMULATIVE .XX±.01 .XXX±.005		
B	5-16-06	Q12064 NOW 501-1209	BG			
A	4-19-06	CUSTOMER PRINT				
ISSUE	DATE	REVISION	BY	PAGE 1 OF 1		