

MECHANICAL

RECOMMENDED PC BOARD LAYOUT

SCHEMATIC

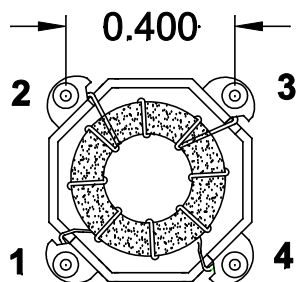
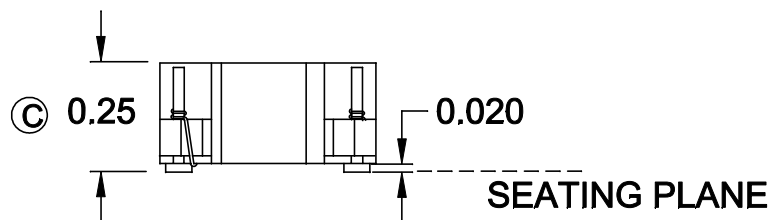
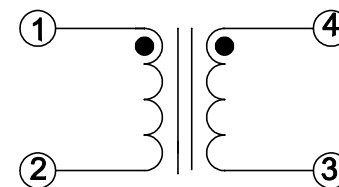
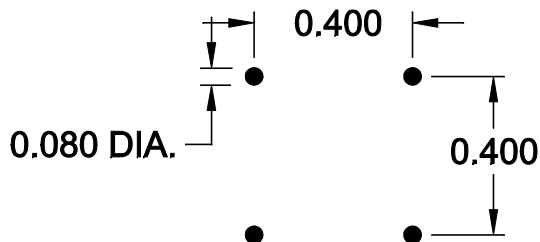
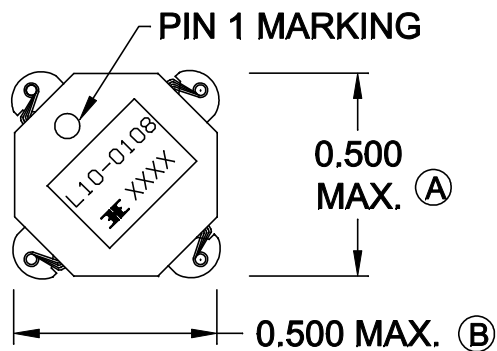

△ COPLANARITY 0.004"

ELECTRICAL SPECIFICATIONS

TURNS RATIO: 3:1

OPEN CIRCUIT INDUCTANCE: 27.48 μ H +/- 20% (1-2) 10 KHz 100mV

DC BIAS: 21.98 μ H TYP. @ 2.5 ADC (1-2) 10 KHz 100mV

DC RESISTANCE: 0.15 OHMS MAX. (1-2)

0.04 OHMS MAX. (3-4)

HIGH VOLTAGE TEST: 3000 VAC (1-4)

A	5-3-10	CUSTOMER PRINT	JDC
ISSUE	DATE	REVISION	BY

DESIGN PER:	BH CATALOG
<input type="checkbox"/> CUSTOM	<input checked="" type="checkbox"/> NON-PROPRIETARY
DRAWN:	K. LOFTUS
ENGR:	J. DECRAMER
UNLESS OTHERWISE SPECIFIED: DIMENSIONS IN INCHES, TOLERANCES NON-CUMULATIVE .XX \pm .01 .XXX \pm .005	
PAGE 1 OF 2	



[®] BH ELECTRONICS, INC.
BURNSVILLE & MARSHALL, MN

© 1998 BH Electronics

TITLE:
3:1 FLYBACK TRANSFORMER

PART NO.
L10-0108

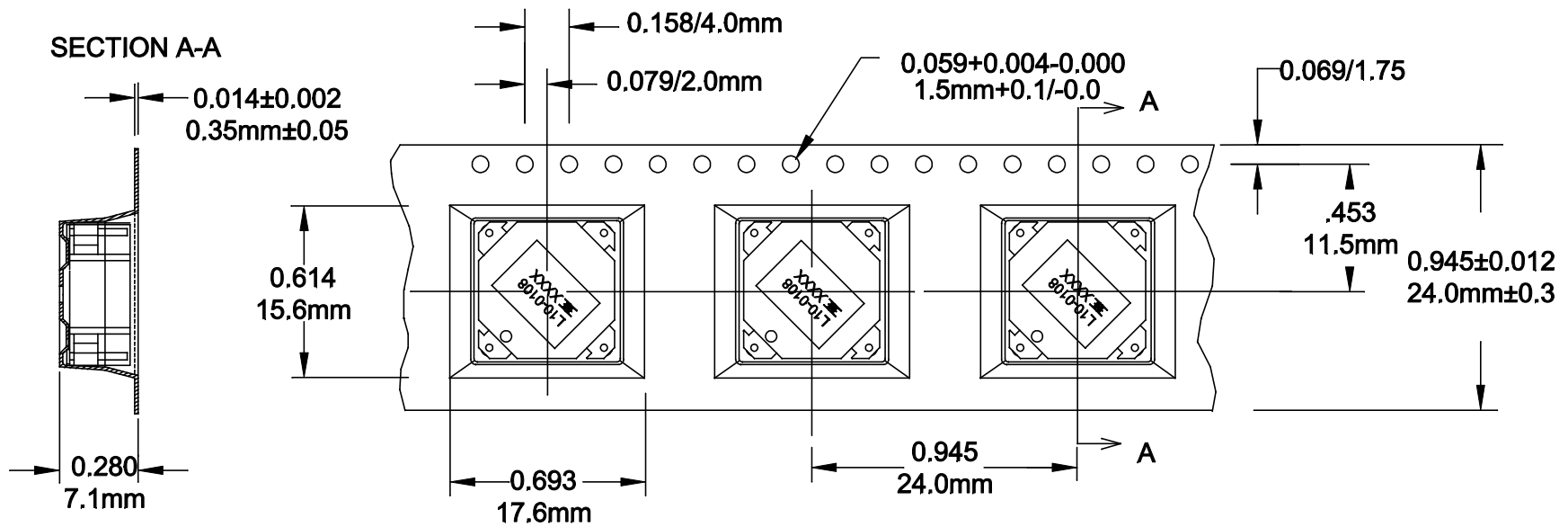

CARRIER TAPE 811-0137

DESIGNED PER:

BH CATALOG

CUSTOM NON-PROPRIETARY

DRAWN Kathy Loftus

ENGR. J. DECRAMER

UNLESS OTHERWISE SPECIFIED:
DIMENSIONS IN INCHES, TOLERANCES
NON-CUMULATIVE.

.XX±.01 .XXX±.005

PAGE 2 OF 2



® BH Electronics, Inc.
Burnsville & Marshall, MN

© 1998 BH Electronics

TITLE:

3:1 FLYBACK TRANSFORMER

PART NO.

L10-0108

A	5-3-10	CUSTOM PRINT	
---	--------	--------------	--

ISSUE	DATE	REVISION	BY
-------	------	----------	----