

MECHANICAL

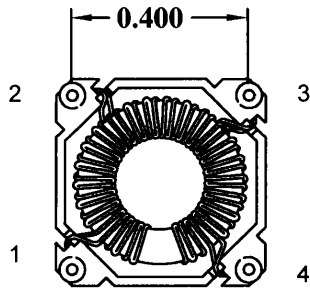

COPLANARITY 0.004" [0.1016]

RECOMMENDED PC BOARD LAYOUT

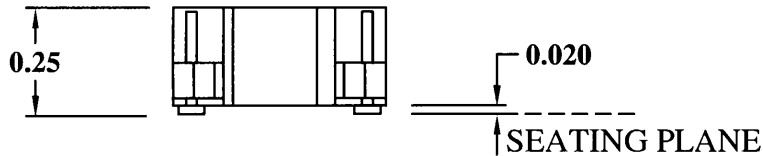
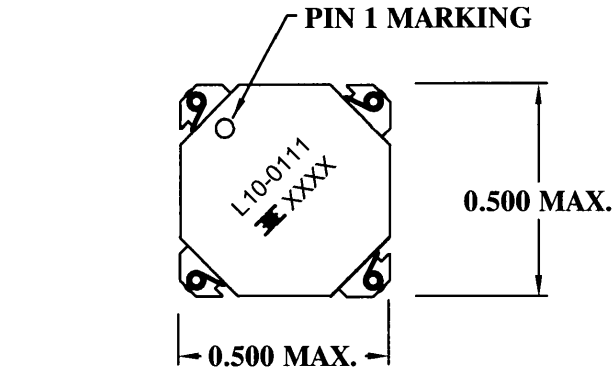
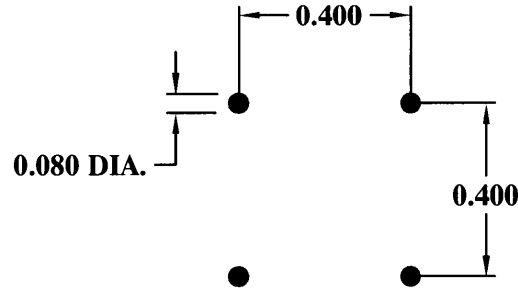

SCHEMATIC

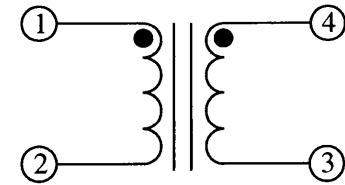

ELECTRICAL SPECIFICATIONS

URNS RATIO: 1:2

OPEN CIRCUIT INDUCTANCE: 150.0µH ±20% @ 0 ADC (1-2)
10 KHz 100mV



DC BIAS: 141.0µH TYP. @ 1.1 ADC (1-2)
10 KHz 100mV

DC RESISTANCE: 0.64 OHMS NOM. (1-2)
2.94 OHMS NOM. (4-3)

HIGH VOLTAGE TEST: 1000 VAC (1-4)

PRIMARY LEAKAGE INDUCTANCE: 1.29µH NOM. (1-2) (SH 4, 3) 120 KHz 50mV

RoHS Compliant

				DESIGN PER:	BH CATALOG	 BH ELECTRONICS, INC. BURNSVILLE & MARSHALL, MN © 1998 BH Electronics
				<input checked="" type="checkbox"/> CUSTOM	<input type="checkbox"/> NON-PROPRIETARY	
				DRAWN:	K. LOFTUS	
				ENGR:	J. DECRAMER	
B	8-9-11	Q12786-4 NOW L10-0111		UNLESS OTHERWISE SPECIFIED: DIMENSIONS IN INCHES, TOLERANCES NON-CUMULATIVE .XX±.01 .XXX±.005		TITLE:
A	4-26-11	CUSTOMER PRINT	JDC			
ISSUE	DATE	REVISION	BY	PAGE 1 OF 1		PART NO.
						L10-0111

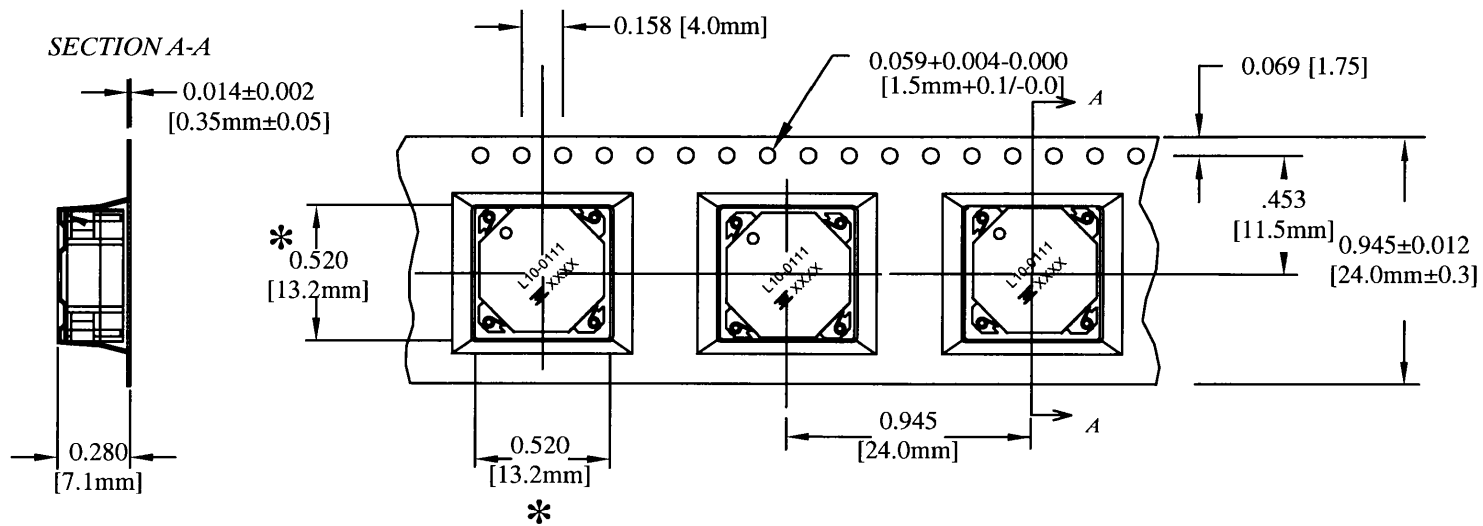

CARRIER TAPE 811-0137

				DESIGN PER:	BH CATALOG	 BH ELECTRONICS, INC. BURNSVILLE & MARSHALL, MN © 1998 BH Electronics
				<input type="checkbox"/> CUSTOM	NON-PROPRIETARY <input checked="" type="checkbox"/>	
				DRAWN:	K. LOFTUS	
				ENGR:	J. DECRAMER	
B	8-9-11	Q12786-4 NOW L10-0111		UNLESS OTHERWISE SPECIFIED: DIMENSIONS IN INCHES, TOLERANCES NON-CUMULATIVE .XX±.01 .XXX±.005		TITLE:
A	4-26-11	CUSTOMER PRINT	JDC			(Switching Regulator)
ISSUE	DATE	REVISION	BY			PART NO.
				PAGE 2 OF 2	L10-0111	