

MECHANICAL

SUGGESTED PAD LAYOUT

SCHEMATIC

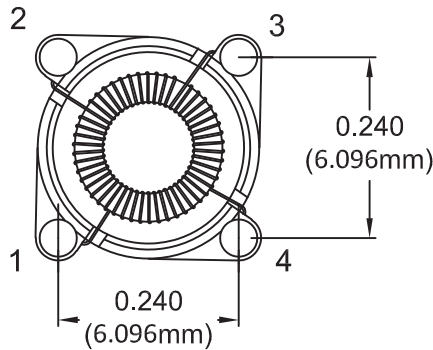
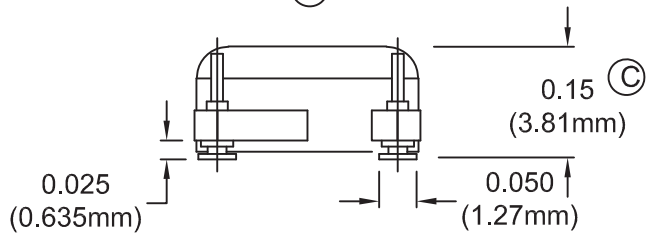
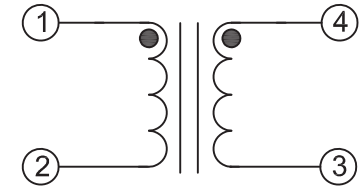
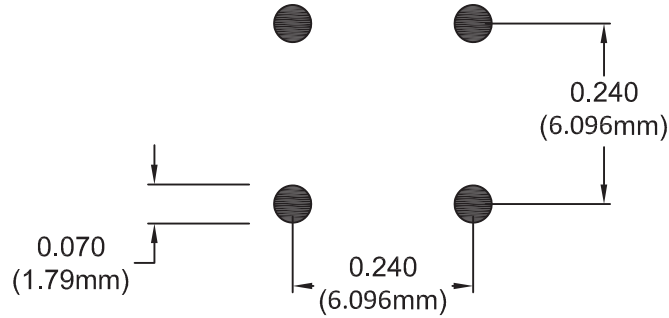
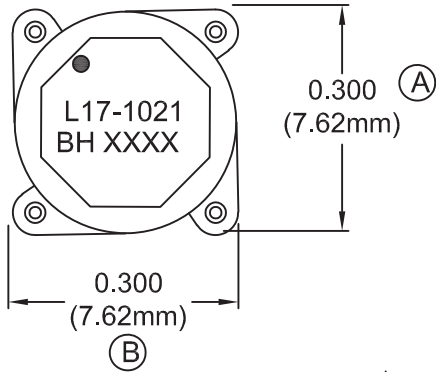

COPLANARITY 0.004 MAX.

ELECTRICAL SPECIFICATIONS

URNS RATIO: 1:1

OPEN CIRCUIT INDUCTANCE: 20.80 $\mu\text{H} \pm 10\%$ @ 0 ADC (1, 4 - 2, 3)
10 KHz 20mV

DC BIAS: 13.53 μH TYP. @ 1.55 ADC (1, 4 - 2, 3)
10 KHz 20mV

DC RESISTANCE: 0.245 OHMS MAX. (1, 4 - 2, 3)

IR: 1K MEGOHMS MIN. @ 100 VDC (1-4)

PRIMARY LEAKAGE: 0.22 μH NOM (1-2 SH 3,4)
120 KHz 50mV

DESIGN PER:

BH CATALOG

CUSTOM NON-PROPRIETARY

DRAWN: KALANI SA

ENGR: NATE DOOSE

UNLESS OTHERWISE SPECIFIED:
DIMENSIONS IN INCHES, TOLERANCES
NON-CUMULATIVE
.XX \pm .01 .XXX \pm .005

PAGE 1 OF 1



BH ELECTRONICS, INC.
BURNSVILLE & MARSHALL, MN

© 1998 BH Electronics

TITLE:

INDUCTOR

PART NO.

L17-1021

ISSUE	DATE	REVISION	BY
B	5-22-19	UPDATE FOOT PAD DIMENSIONS	ngs
A	5-21-19	CUSTOMER PRINT	NGD